

MULTIPLE BRUSHES EQUIPPED WITH TRIP LEVERS
METHOD OF TESTING FALSE CLOSURE (SIDESWIPING)
USING PORTABLE FALSE CLOSURE TEST SET
PANEL OFFICES

1. GENERAL

1.01 This section describes a method of testing for momentary false closures (sideswiping) of multiple brushes in the reset position by means of the portable false closure test set.

1.02 This section is reissued to add Fig 1.

1.03 This test verifies that none of the multiple brushes on the selector rod make falsely when the rod is driven, electrically, over the entire length of the multiple bank or when the brush is rotated to the left and right while stopped in the middle of the bank.

1.04 When making this test, care should be exercised to see that some potential exists on all terminals which the brushes may touch during the rotating portion of the test (in the middle of the bank). The test may not recognize false closure with a vacant terminal or overflow terminal.

1.05 When testing brushes on incoming selectors, two-wire office selectors, operator districts, or tandem districts, the circuits should be taken out of service at the originating appearance in the approved manner before beginning the tests.

1.06 The false closure test set should be connected to the 110-volt and 48-volt power sources and turned on for several minutes to stabilize at the working temperature, and then adjusted for sensitivity each time these tests are performed. Repeat the adjusting procedure at hourly intervals if no indications of multiple brush troubles occur.

1.07 When reference is made in this section to the release buttons, it is to be understood that the statement applies to both the panel-mounted release button and the remote release button.

1.08 If the test set does not function properly, the minor corrective measures indicated in Part 4 may be applied if approved locally.

1.09 *Lettered Steps:* A letter a, b, c, etc, added to a step number in Part 3 of this section, indicates an action which may or may not be required depending on local conditions. The condition under which a lettered step or a series of lettered steps should be made is given in the ACTION column, and all steps governed by the same condition are designated by the same letter within a test. When a condition does not apply, all steps designated by that letter should be omitted.

2. APPARATUS

2.01 False closure test set 38-Y-3892.

2.02 Testing cord, 2W17A and two 419A tools; or two testing cords, 1W13B with two 419A tools and two 364 tools (spade terminals).

2.03 Patching cord, 3P7A.

2.04 Remote release cord made locally. Consists of one 2W5B cord connected to one 92AC nonlocking key. After connecting key to cord, insulate the key by wrapping it with 1/64-inch sheet fiber and then with 3/8-inch friction tape. Continue the wrap so that it covers one inch of the cord, thereby securing the key to the cord.

2.05 Testing cord, 1W13A and one KS-6278 connecting clip.

2.06 Blocking and insulating tools, as required. Use tools and apply in accordance with approved procedure.

3. METHOD

3.01 The objective in setting the sensitivity of the test set is to reach that setting at which the test set will signal a momentary cross with

battery or ground. Excessive sensitivity will result in false test set signals when the leads are touched with the hands or will cause false indications while the leads are connected to the multiple brush springs.

STEP	ACTION	VERIFICATION
1	Place test set in horizontal position. <i>Note:</i> When used on rolling ladders, the set should be fastened to the side of the ladder by means of the strap.	
2	Using 3P7A cord, patch battery and ground supply to test set.	
3	Connect power supply cord of test set to source of 110-volt power.	
4a	If remote release test cord is to be used— Place remote release cord plug in REMOTE RELEASE jack.	
5	Operate POWER switch to ON position.	Power pilot lamp (red) lights.
6	Take equipment out of service as required (see 1.04).	
7b	If 2W17A cord is used— Insert 310 plug of 2W17A cord into T-R jack.	
8c	If 1W13B cords are used— Connect 364 tools (spade terminals) to T-R binding posts.	
9	Permit sufficient time to elapse before adjusting sensitivity so that the electron tubes can warm up and the test set temperature can stabilize (approximately 5-10 minutes).	
10	Turn both sensitivity controls to extreme counterclockwise position.	
11b	If 2W17A cord is used— Hold 419A tool associated with tip conductor to battery.	
12c	If 1W13B cords are used— Hold 419A tool associated with tip test cord to battery.	

STEP	ACTION	VERIFICATION
13	Turn tip sensitivity control <i>slowly</i> in clockwise direction until tip trouble lamp lights and buzzer sounds.	Tip lamp lights. Buzzer sounds.
14	Remove 419A tool associated with tip cord from battery.	
15	Operate RELEASE key.	Tip lamp extinguished. Buzzer silenced.
16	Repeat Steps 11b through 15 holding 419A tool to ground instead of battery.	
17	To adjust sensitivity of ring side of test circuit; repeat Steps 11b through 16 using the 419A tool associated with the ring of test circuit, the ring sensitivity control, and the ring trouble lamp.	
18	Connect the tip side of the test set to the tip spring of the No. 0 multiple brush and the ring side of the test set to the ring spring of the No. 0 multiple brush, using the 419A tools. <i>Note:</i> If the sensitivity of either side of the test set is so great that touching the 419A tools or connecting them to the springs of the multiple brush causes the test set alarms to operate, readjust the sensitivity (see 3.01).	
19	Consult circuit drawings to determine what protective measures (such as blocking relays or sequence switches) may be required to avoid interference when the selector rods are driven to telltale position and down again.	
20d	If blocking of apparatus is required— Block apparatus as indicated by circuit drawing.	
21	Using the 1W13B cord equipped with KS-6278 clip, connect the clip to ground.	
22	Hold the 360A tool on the free end of the cord to updrive terminal of clutch associated with selector rod under test, until selector rod reaches telltale.	Selector rides to telltale. All brushes are in reset position. Trouble lamps do not light. Buzzer does not sound.
		<i>Note:</i> Lighted lamp and sounding buzzer indicate false closure.

STEP	ACTION	VERIFICATION
23e	If trouble lamp lights and buzzer sounds— Operate RELEASE key.	Lamp extinguished. Buzzer silenced.
24	Touch 360A tool to downdrive terminal until brushes are approximately in center of bank. <i>Note:</i> Check to see that the brushes are opposite terminals which contain some potential (see 1.03).	
25	Rotate the brush rod until the back of the insulating shoe associated with the sleeve spring touches the back of the ring terminal, then in the opposite direction until the back of the insulating shoe associated with the sleeve or hunt spring touches the back of the tip terminal. <i>Note:</i> It will be satisfactory to observe one brush on each selector rod.	Trouble lamps do not light. Buzzer does not sound. <i>Note:</i> Lighted lamp and sounding buzzer indicates false closure.
25e	If trouble lamp lights and buzzer sounds— Operate RELEASE key.	Lamp extinguished. Buzzer silenced.
26	Restore the selector rod to normal.	
27	Remove test connections from No. 0 multiple brush.	
28d	If blocking of apparatus was required— Remove blocking tools.	
29	Restore selector circuit to service.	
30	Repeat Steps 6 and 18 through 29, as required, on other selectors to be tested.	
31	Operate test set POWER switch to OFF position and remove all test cords.	

4. TEST SET MAINTENANCE

4.01 Local procedures may differ regarding the disposition of defective 38-Y-3892 test sets. Minor repairs may be permitted. This portion of the section may prove helpful to that end. See Table A and Fig. 1. If the information included herein does not clear the trouble, the matter should be referred to the supervisor.

4.02 Any suitable volt-ohmmeter (such as the KS-14510 volt-ohm-milliammeter) is all that is required to perform the following tests.

4.03 When using the volt-ohmmeter, the test set must be disconnected from the ac line and the battery and ground supply.

4.04 Pilot Lamp Does Not Light: Observe that the 110-volt power cord is connected and that the power switch is in the ON position, then proceed as follows:

- (1) If the filaments of the electron tubes are lighted, disconnect the set from the ac line and replace the pilot lamp.

TABLE A

CIRCUIT REQUIREMENTS													CR		
FALSE CLOSURE TEST SET															
APPARATUS		MECH REQ			CIRCUIT PREPARATION				TEST SET PREP	SEE TEST NOTE	DIRECT CURRENT FLOW REQ				REMARKS
DESIG	CODE	BSP FIG.	CONT PRES	ARM TRVL	SEQ SW POS	BLOCK OR INSULATION	TEST CLIP DATA				TEST WDG	TEST FOR	MILLIAMPERES		
							CONN BAT.	CONN GRD	AFTER SOAK	TEST			READJ		
T	B421			30			1M	2M	B,G	I	O	1.1	1		
							1M	2M	B,G	I	R	0.1	0.2		
R	B421			30			1M	2M	B,G	I	O	1.1	1		
							1M	2M	B,G	I	R	0.1	0.2		
TEST NOTE: TEST SET MUST BE DISCONNECTED FROM AC LINE AND B AND G JACK.															

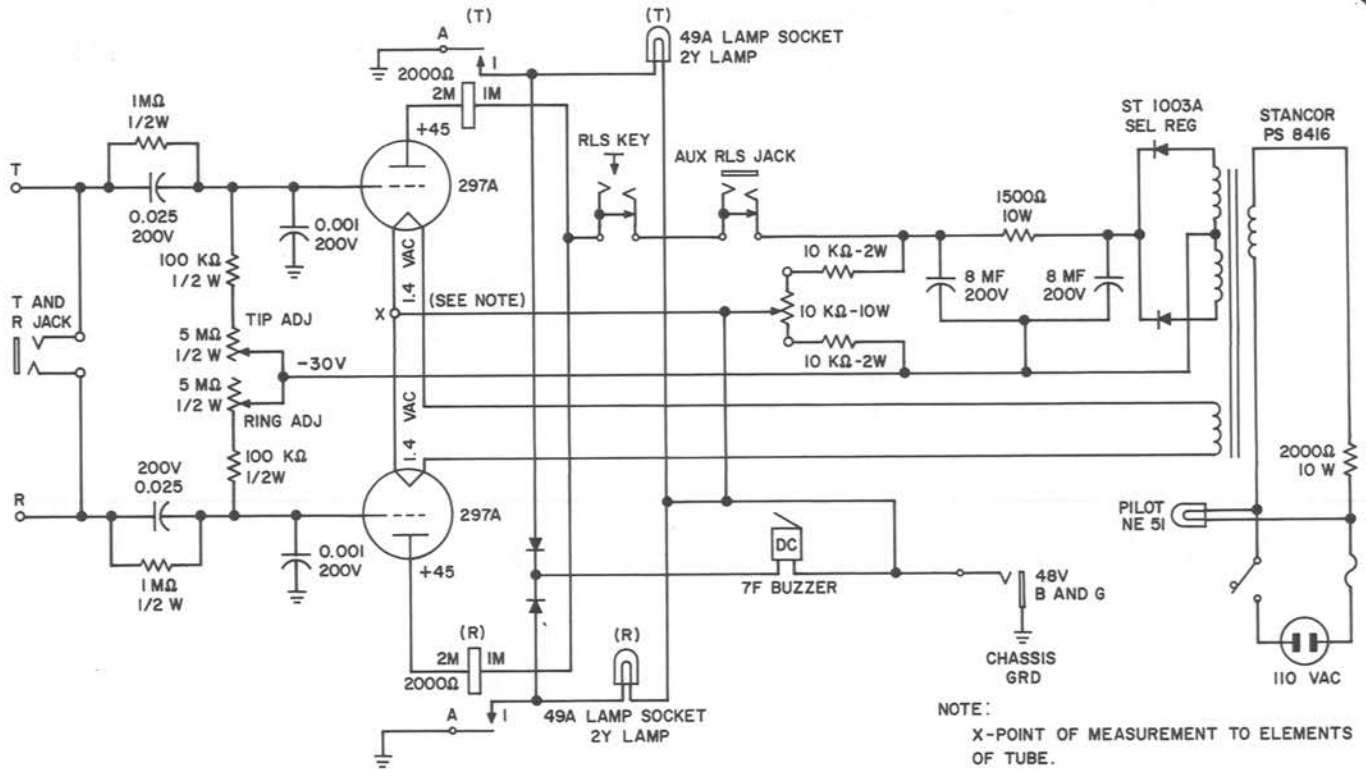

Fig. 1—Schematic of 38-Y-3892 False Closure Test Set

- (2) If the filaments of the electron tubes are not lighted, disconnect the set from the ac line and check the fuse, power switch, and source of 110-volt power.

4.05 Only One Side of Circuit Functions

Properly: If only the tip test lead, or only the ring test lead, recognizes a cross with a foreign potential, proceed as follows (after first determining that the trouble is not an improperly adjusted rheostat):

- (1) If the trouble relay fails to operate, replace the electron tube.
- (2) If the trouble relay operates, but the light and buzzer do not function; check the relay using the circuit requirements in Table A and the appropriate Bell System Practice covering the relay.
- (3) If the electron tube is good and the trouble relay does not operate, check the relay as covered in 4.06.

4.06 If the Relays Require Adjusting: Disconnect the 110-volt power cord and the battery and ground cord, then proceed as follows:

- (1) Adjust the relay in accordance with the appropriate Bell System Practice.

- (2) Apply the electrical requirements using Table A.

- (3) If the relay does not function properly after adjustment, replace it.

4.07 If Buzzer Sounds and Trouble Lamp Fails to Light:

Determine which lamp is defective by crossing each test lead with battery or ground and observing which lamp fails to light. Then replace the defective lamp.

4.08 If Neither Side of the Circuit Functions Properly and Power Lamp Is Lighted:

Proceed as follows:

- (1) If electron tube filaments are not lighted (filaments are connected in series), replace tubes individually to determine if one has a defective filament.
- (2) Test normally closed contacts of RLS key and AUX-RLS jack.